



Main

Range	TeSys
Product name	TeSys D
Product or component type	Reversing contactor
Device short name	LC2D
Contactors application	Motor control Resistive load
Utilisation category	AC-1 AC-3
Device presentation	Preassembled with reversing power busbar
Poles description	3P
Power pole contact composition	3 NO
[Ue] rated operational voltage	≤ 300 V DC for power circuit ≤ 690 V AC 25...400 Hz for power circuit
[Ie] rated operational current	50 A (≤ 60 °C) at ≤ 440 V AC AC-3 for power circuit 80 A (≤ 60 °C) at ≤ 440 V AC AC-1 for power circuit
Motor power kW	15 kW at 220...230 V AC 50/60 Hz 22 kW at 380...400 V AC 50/60 Hz 25 kW at 415 V AC 50/60 Hz 30 kW at 440 V AC 50/60 Hz 30 kW at 500 V AC 50/60 Hz 33 kW at 660...690 V AC 50/60 Hz
Motor power HP (UL / CSA)	3 hp at 115 V AC 50/60 Hz for 1 phase motors 7.5 hp at 230/240 V AC 50/60 Hz for 1 phase motors 15 hp at 200/208 V AC 50/60 Hz for 3 phases motors 15 hp at 230/240 V AC 50/60 Hz for 3 phases motors 40 hp at 460/480 V AC 50/60 Hz for 3 phases motors 40 hp at 575/600 V AC 50/60 Hz for 3 phases motors
Control circuit type	AC 50/60 Hz
[Uc] control circuit voltage	220 V AC 50/60 Hz
Auxiliary contact composition	1 NO + 1 NC
[Uimp] rated impulse withstand voltage	6 kV conforming to IEC 60947
Overvoltage category	III
[Ith] conventional free air thermal current	80 A at ≤ 60 °C for power circuit 10 A at ≤ 60 °C for signalling circuit
Irms rated making capacity	900 A at 440 V for power circuit conforming to IEC 60947 140 A AC for signalling circuit conforming to IEC 60947-5-1 250 A DC for signalling circuit conforming to IEC 60947-5-1

Disklaimer: Dokumentasi ini tidak ditujukan sebagai pengganti dan tidak digunakan untuk menentukan kesesuaian atau keandalan produk ini untuk aplikasi pengguna

Rated breaking capacity	900 A at 440 V for power circuit conforming to IEC 60947
[Icw] rated short-time withstand current	100 A 1 s signalling circuit 120 A 500 ms signalling circuit 140 A 100 ms signalling circuit 400 A ≤ 40 °C 10 s power circuit 810 A ≤ 40 °C 1 s power circuit 84 A ≤ 40 °C 10 min power circuit 208 A ≤ 40 °C 1 min power circuit
Associated fuse rating	100 A gG at ≤ 690 V coordination type 1 for power circuit 100 A gG at ≤ 690 V coordination type 2 for power circuit 10 A gG for signalling circuit conforming to IEC 60947-5-1
Average impedance	At 50 Hz - Ith 80 A for power circuit
[Ui] rated insulation voltage	600 V for power circuit certifications CSA 600 V for power circuit certifications UL 690 V for power circuit conforming to IEC 60947-4-1 690 V for signalling circuit conforming to IEC 60947-1 600 V for signalling circuit certifications CSA 600 V for signalling circuit certifications UL
Electrical durability	1.45 Mcycles 50 A AC-3 at Ue ≤ 440 V 1.1 Mcycles 80 A AC-1 at Ue ≤ 440 V
Power dissipation per pole	3.7 W AC-3 9.6 W AC-1
Safety cover	With
Interlocking type	Mechanical
Mounting support	Plate Rail
Standards	CSA C22.2 No 14 EN 60947-4-1 EN 60947-5-1 IEC 60947-4-1 IEC 60947-5-1 UL 508
Product certifications	CCC CSA GOST UL
Connections - terminals	Control circuit : screw clamp terminals 2 cable(s) 1...2.5 mm ² - cable stiffness: flexible - with cable end Power circuit : EverLink BTR screw connectors 1 cable(s) 1...35 mm ² - cable stiffness: flexible - without cable end Power circuit : EverLink BTR screw connectors 1 cable(s) 1...35 mm ² - cable stiffness: flexible - with cable end Power circuit : EverLink BTR screw connectors 1 cable(s) 1...35 mm ² - cable stiffness: solid - without cable end Power circuit : EverLink BTR screw connectors 2 cable(s) 1...25 mm ² - cable stiffness: flexible - without cable end Power circuit : EverLink BTR screw connectors 2 cable(s) 1...25 mm ² - cable stiffness: flexible - with cable end Power circuit : EverLink BTR screw connectors 2 cable(s) 1...25 mm ² - cable stiffness: solid - without cable end Control circuit : screw clamp terminals 1 cable(s) 1...4 mm ² - cable stiffness: flexible - without cable end Control circuit : screw clamp terminals 2 cable(s) 1...4 mm ² - cable stiffness: flexible - without cable end Control circuit : screw clamp terminals 1 cable(s) 1...4 mm ² - cable stiffness: flexible - with cable end Control circuit : screw clamp terminals 1 cable(s) 1...4 mm ² - cable stiffness: solid - without cable end Control circuit : screw clamp terminals 2 cable(s) 1...4 mm ² - cable stiffness: solid - without cable end
Tightening torque	Control circuit : 1.7 N.m - on screw clamp terminals - with screwdriver flat Ø 6 mm Control circuit : 1.7 N.m - on screw clamp terminals - with screwdriver Philips No 2 Power circuit : 8 N.m - on EverLink BTR screw connectors - cable 25...35 mm ² hexagonal 4 mm Power circuit : 5 N.m - on EverLink BTR screw connectors - cable 1...25 mm ² hexagonal 4 mm
Operating time	12...26 ms closing 4...19 ms opening
Safety reliability level	B10d = 1369863 cycles contactor with nominal load conforming to EN/ISO 13849-1 B10d = 20000000 cycles contactor with mechanical load conforming to EN/ISO 13849-1
Mechanical durability	6 Mcycles
Operating rate	3600 cyc/h at ≤ 60 °C

Complementary

Coil technology	Without built-in suppressor module
Control circuit voltage limits	0.3...0.6 Uc drop-out at 60 °C, AC 50/60 Hz 0.8...1.1 Uc operational at 60 °C, AC 50 Hz 0.85...1.1 Uc operational at 60 °C, AC 60 Hz
Inrush power in VA	140 VA at 20 °C (cos ϕ 0.75) 60 Hz 160 VA at 20 °C (cos ϕ 0.75) 50 Hz
Hold-in power consumption in VA	13 VA at 20 °C (cos ϕ 0.3) 60 Hz 15 VA at 20 °C (cos ϕ 0.3) 50 Hz
Heat dissipation	4...5 W at 50/60 Hz
Auxiliary contacts type	Type mechanically linked (1 NO + 1 NC) conforming to IEC 60947-5-1 Type mirror contact (1 NC) conforming to IEC 60947-4-1
Signalling circuit frequency	25...400 Hz
Minimum switching current	5 mA for signalling circuit
Minimum switching voltage	17 V Signalling circuit
Non-overlap time	1.5 ms on de-energisation (between NC and NO contact) 1.5 ms on energisation (between NC and NO contact)
Insulation resistance	> 10 MOhm for signalling circuit

Environment

IP degree of protection	IP20 front face conforming to IEC 60529
Protective treatment	TH conforming to IEC 60068-2-30
Pollution degree	3
Ambient air temperature for operation	-5...60 °C
Ambient air temperature for storage	-60...80 °C
Permissible ambient air temperature around the device	-40...70 °C at Uc
Operating altitude	3000 m without derating in temperature
Fire resistance	850 °C conforming to IEC 60695-2-1
Flame retardance	V1 conforming to UL 94
Mechanical robustness	Vibrations contactor open 2 Gn, 5...300 Hz Vibrations contactor closed 4 Gn, 5...300 Hz Shocks contactor open 10 Gn for 11 ms Shocks contactor closed 15 Gn for 11 ms
Height	122 mm
Width	119 mm
Depth	120 mm
Product weight	1.88 kg

Contractual warranty

Warranty period	18 months
-----------------	-----------

Dimensions

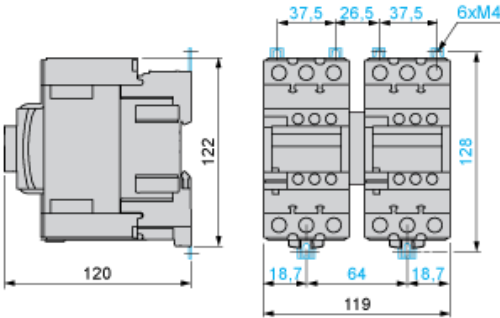

Wiring

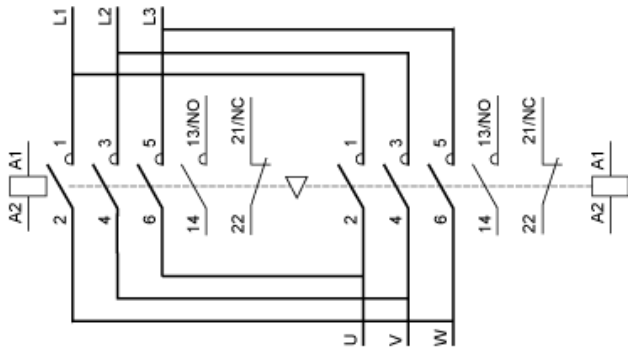

Our Proposal - Type 1 : Circuit Breaker + Contactor for Motor Power 22 kW and 415 VAC

Motor power (kW)	ICU (kA)	Breaker	Contactor (*)
22	50	 GV3P50	 LC2D50AM7

Non contractual pictures.

Type 1 coordination requires that in a short-circuit condition, the contactor or starter must not present any danger to personnel or installations and must not be able to resume operation without repair or the replacement of parts.